



HydroWhirl® Orbitor Tank Washing Machine



Instruction and Maintenance Manual

BETE Fog Nozzle Inc.
www.bete.com

Contents

Maintenance 3

Recommended Tools List 5

Nozzle Head and Rear Plate – Disassembly 6

Body Shell and Inlet Casing – Disassembly 8

Turbine Shaft Subassembly – Disassembly 9

Gear Cartridge Subassembly – Disassembly 10

Main Body and Body Shell – Disassembly 11

Main Body and Body Shell – Reassembly 13

Gear Cartridge Subassembly – Reassembly 14

Turbine Shaft Subassembly – Reassembly 14

Body Shell and Inlet Casing – Reassembly 15

Nozzle Head and Rear Plate – Reassembly 16

Appendix 18

 Parts List 21

 Interchangeable Parts 22

 Recommended Spare Parts 23

Maintenance

In order to prevent machine failures, routine maintenance should be carried out every 500 hours of operation. This should include cleaning all internal parts and assessing the wear of seals, gears, bearing and bushes.

Any fine solid particles left inside the machine will increase wear considerably.

Please Note:

- **The Orbitor requires no lubrication.**
- **The Orbitor is approved by Bureau Veritas; a copy of certification can be provided upon request.**
- **The Orbitor is available with ATEX approval for Zone 0.**

Attention

- Before maintenance can be carried out, it is important the machine is not contaminated with chemicals that could be hazardous.
- Always use the tools stated throughout this manual. These can be purchased from BETE.
- Always read the technical data thoroughly before carrying out any work on this machine.
- Never service the Orbitor head while it is hot.
- After any maintenance is carried out it is essential the machine is flushed and sterilized before further use.
- Any parts found to be unserviceable should be replaced before further use.
- The machine should only be operated at temperatures below 95°C (200°F)
- During operation, always ensure any tank openings are completely sealed off and can withstand the full force of the striking jet.
- If the tank being cleaned contains a combustible liquid or vapor with a risk of ignition or explosion, the Orbitor should be properly grounded.

- The machine should be allowed to gradually reach its operating pressure. A sudden spike could cause parts to wear prematurely or fail.

Please Note – Any cleaning fluids must be stored/disposed of in accordance with current rules/directives.

Please Note – Always record any wear found and ensure the machine operates smoothly after maintenance.

Recommended Tools List

- Allen Keys: (1) 6 mm and (1) 3 mm
- M12 Wrench
- Strap Wrench
- Screwdriver
- 3 mm Pin Punch
- Light Hammer
- Vice
- Spider Tool (Part No. DM00748)
- Set of (2) Side Plate Tools (Part No. DM00749 for the set)
- Nozzle Head Tool (Part No. DM00750)
- Loctite 638 (if ceramic seals are removed)
- Torque Wrench
- Fly-Press or Soft-Jawed Vice

Nozzle Head and Rear Plate – Disassembly

Please refer to Figures 1 and 2.

1. Place the Orbitor in the vice, holding onto rear plate flats (DM02142). Ensure machine is securely held in place before proceeding to the next step.
2. Use tool (DM00750) to unscrew nozzle head (DM02141), in an anti-clockwise direction.

Please Note – The assembly has 180° of lost motion.

3. The nozzle head (DM02141) should now be free to lift off.
4. Lift machine off the nozzle head shaft (DM02143).

Please Note – Be careful not to lose any seals, spacers or bushes.

5. Check seal in nozzle head (DM00699) for wear or damage to the seal lip, if excessively worn or damaged, then remove by cutting free.
6. There should be a ceramic seal insert (DM00698) left in the main body. This should be replaced if the ceramic coating is chipped or worn.
7. The bush (DM02032) will still be inside the main body (DM02139) and should be carefully assessed for signs of wear.
8. The nozzle head bevel gear (DM02147) should still be on the nozzle head shaft (DM02143) and should also be assessed for any signs of wear to the gear teeth.
9. Inspect the stream straighteners for any foreign bodies and remove if necessary.
10. Check rear plate seal (DM00699) for wear or damage to the seal lip.
11. Turn main body (DM02139) over and inspect second ceramic seal insert for wear or damage.
12. Now both bushes (DM02032) in main head can be removed but only if they are required to be replaced.
13. Lastly the nozzle head bevel gear (DM02147) can be lifted off the nozzle shaft.
14. For Hi-capacity version see Figure 13.

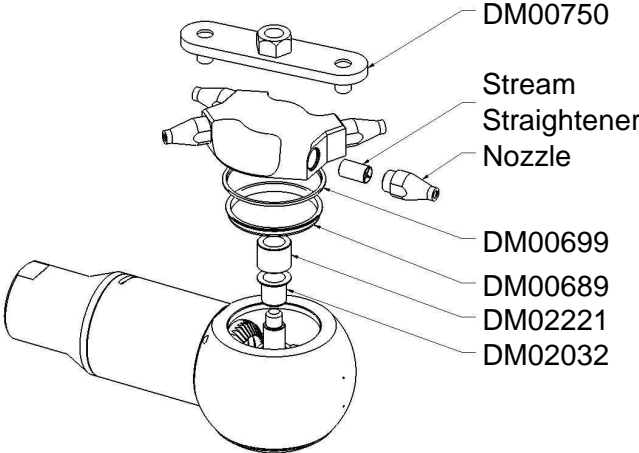

Figure 1: Nozzle head removal

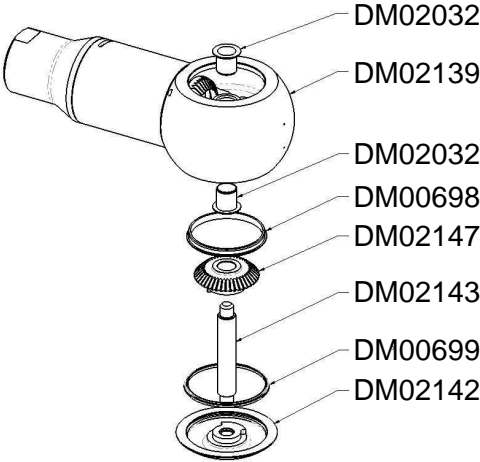
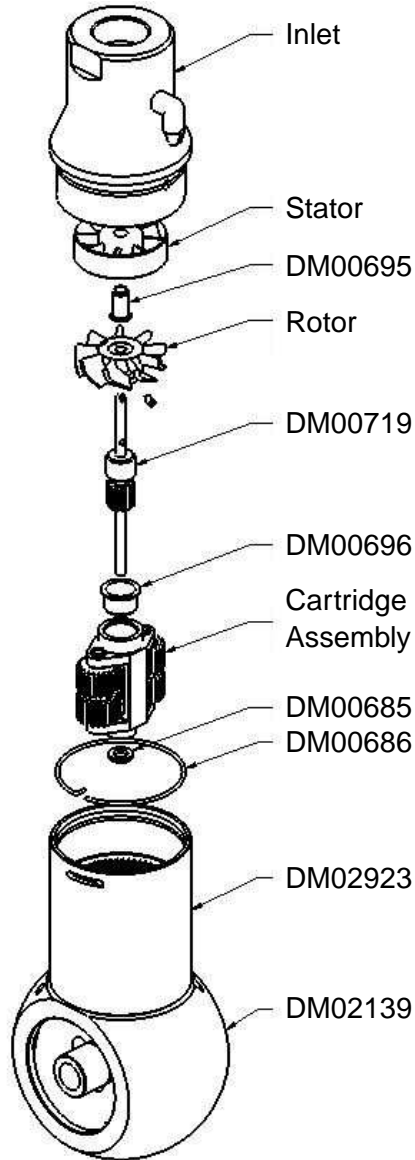

Figure 2: Back plate disassembly

Body Shell and Inlet Casing – Disassembly



1. Hold machine by inlet casing at the bottom and turn the body shell (DM02140) counter-clockwise by hand, or alternatively with a strap wrench if tight.

Please Note – To find part number for a specific Inlet Casing please refer to the Interchangeable Parts list in the Appendix as they vary by model.

2. This should allow spring clip (DM00686) to extrude from slot. Unhook clip using a screwdriver.
3. Lift shell (DM02140) up from Inlet.

Please Note – You should be left with the cartridge and turbine subassemblies in inlet.

4. Pull out cartridge and turbine assemblies and inspect for wear.
5. Remove stator bush (DM00695) if necessary.

Figure 3: Body shell and inlet casing

Turbine Shaft Subassembly – Disassembly

Please Note – Turbine can be removed from shaft if necessary by unscrewing Hollow Set Screw (DM00702) (see Figure 4). For specific turbine (rotor) part numbers refer to Interchangeable Parts list in the Appendix as these vary depending on machine.

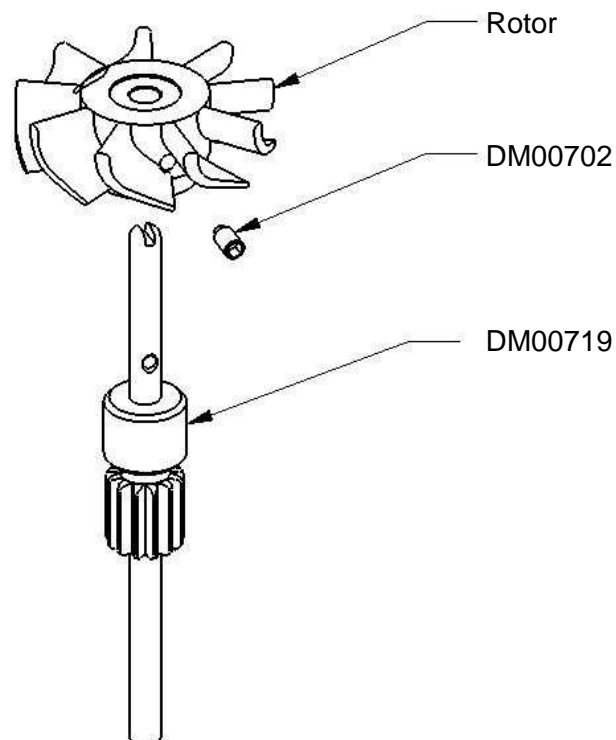

Figure 4: Rotor (turbine) subassembly

Gear Cartridge Subassembly – Disassembly

1. Check cartridge bush (DM00696), shaft bushes (DM00697), and support washer (DM02226); inspect for wear.
2. Unscrew hollow set screws (DM00702) in both planet shafts, this should allow you to remove both shafts (DM00736).
3. Now remove the planet gears; both the Aligned (DM00721) and the $\frac{1}{2}$ Displaced (DM00722); check for wear.

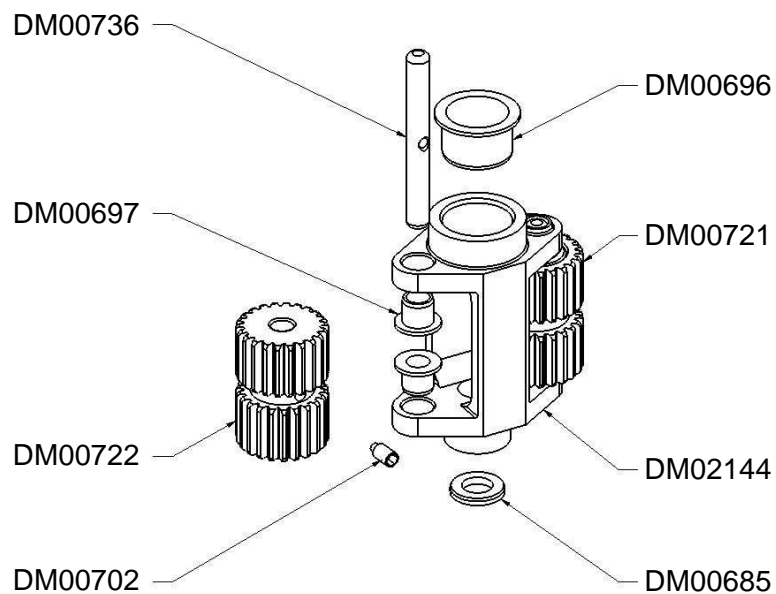

Figure 5: Gear cartridge subassembly

Main Body and Body Shell – Disassembly

Please Note – Before attempting to unscrew shell from main body, ensure you knock pin out of main body using a 3mm pin punch (Figure 6).

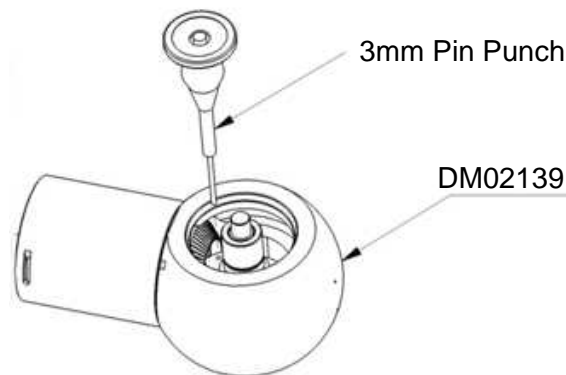

Figure 6: 3mm Pin Punch

1. Fit the two side plate tools (DM00749) to the faces of the body and place in vice.
2. Using spider tool (DM00748), loosen spider (DM02145 Figures 7 and 8) from main body.
3. Lift shell and spider from ball and separate internal components to ensure all thrust bearing balls (DM00703) are retained. (Figure 8).
4. Inspect all seals, bearings, and bushes for signs of wear and replace if necessary.
5. Check spider and bevel gear teeth for wear.
6. Check ceramic seal insert (DM00698) on body shell.

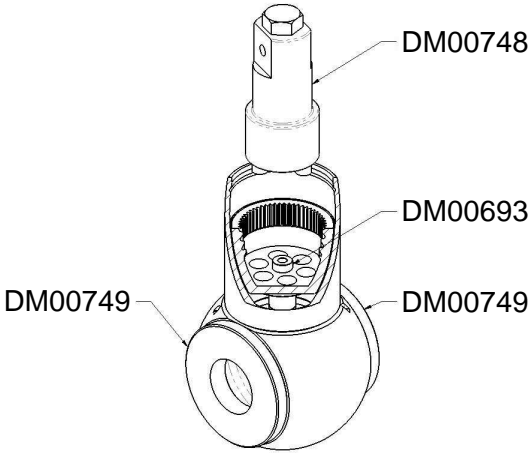

Figure 7: Assembly and disassembly tool

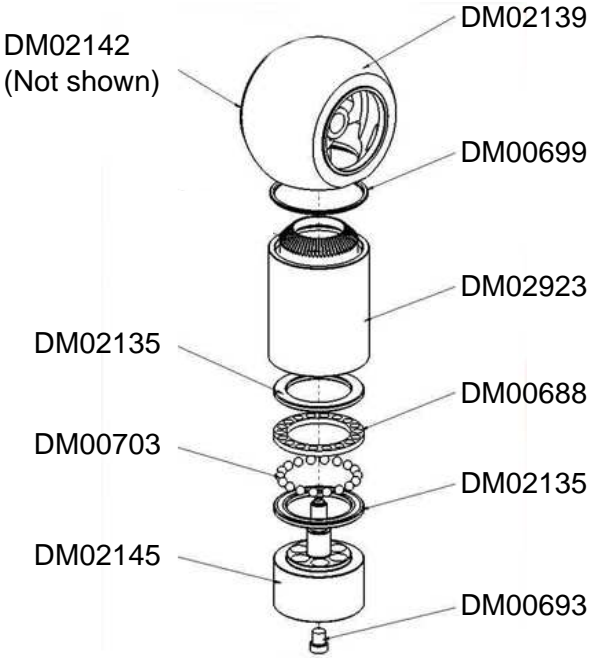

Figure 8: Main body and inlet shell

Main Body and Body Shell – Reassembly

1. If removed, push ceramic seal inserts back into main body and body shell using Loctite 638.
2. Re-assemble bearing assembly to spider and insert into body shell.
3. Pick up the main body and place the side plate tools on the sides of main body and hold in vice.

Please Note – This is to protect the ceramic seal inserts.

4. Insert seal (DM00698) to top of main body, if removed.
5. Locate spider using spider tool and screw assembly to main body through body shell. Using Loctite 638 on thread of spider shaft.
6. Using torque wrench, tighten spider to 60 N·m (45 ft·lb_f).
7. Remove whole assembly from vice and remove side plates.
8. Replace 3mm pin (DM00709) in hole inside main body.

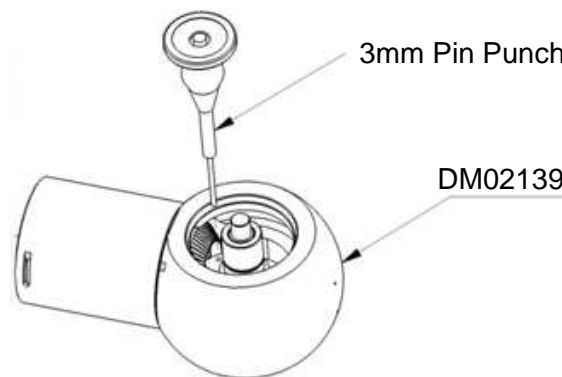

Figure 9: 3 mm Pin Punch

Gear Cartridge Subassembly – Reassembly

1. Replace cartridge bush (DM00696), shaft bushes (DM00697), and support washer (DM02226) if removed.
2. Slide both gears into place and insert shafts aligning holes in gears and shafts for hollow set screw.
3. Insert set screw (DM00702) and tighten.

Turbine Shaft Subassembly – Reassembly

Please Note – Turbine can be replaced on shaft if necessary by sliding onto shaft and reinserting hollow set screw (DM00702). For turbine part number refer to the Interchangeable Parts list in the Appendix.

Body Shell and Inlet Casing – Reassembly

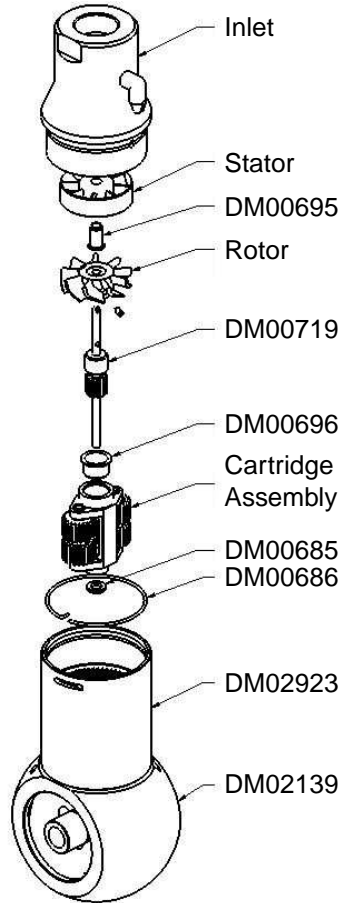

Figure 10: Body shell and inlet casing

1. Hold machine with main body (DM02139) under body shell (DM02923) and insert gear cartridge subassembly.

2. Insert turbine shaft subassembly guiding turbine into cartridge.

Please Note – Check for smooth operation by spinning the turbine shaft by hand.

3. Replace stator bush (DM00695) in stator inside inlet casing, if removed.

4. Hold machine with main body under body shell and slide the inlet casing into body shell.

Please Note – Ensure hole in inlet casing is aligned with slot in main body shell.

5. Fit spring clip through slot in the shell into the hole in the inlet connection and turn slightly to locate in its position.

6. Rotate machine vertically and hold inlet connection in vice, located on flats.

7. Turn shell 360° clockwise to fit spring clip completely in inlet connection.

Please Note – Use new spring clip (DM00686) if necessary.

Please Note – Tighten with strap wrench if necessary.

Nozzle Head and Rear Plate – Reassembly

Please refer to Figures 11 and 12.

1. Hold rear plate in vice using flats and place new seal, if necessary.
2. Slide nozzle head bevel gear onto nozzle shaft.
3. Push bushes (DM02032) into main body if necessary and slide assembly back onto nozzle shaft.
4. Fit stainless steel spacer (DM02221) onto nozzle shaft.
5. If nozzles were removed now replace nozzles to nozzle head.

Please Note – Ensure nozzles are tightened sufficiently in order to avoid machine failure.

6. Locate seal into groove of nozzle head.
7. Finally screw nozzle head back onto main assembly using Loctite 638 and tighten with tool (DM00750) to 60 N·m (45 ft·lb_f).
8. For Hi-capacity version, see Figure 13.

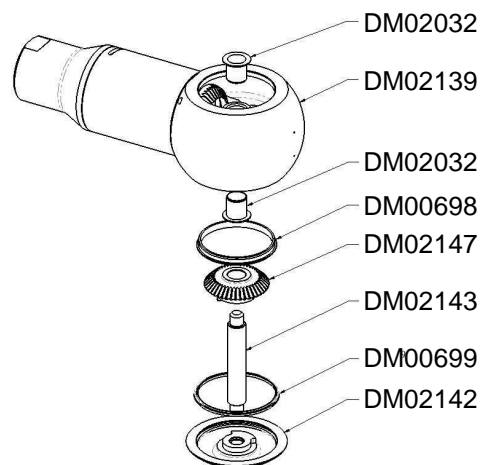

Figure 11: Back plate reassembly

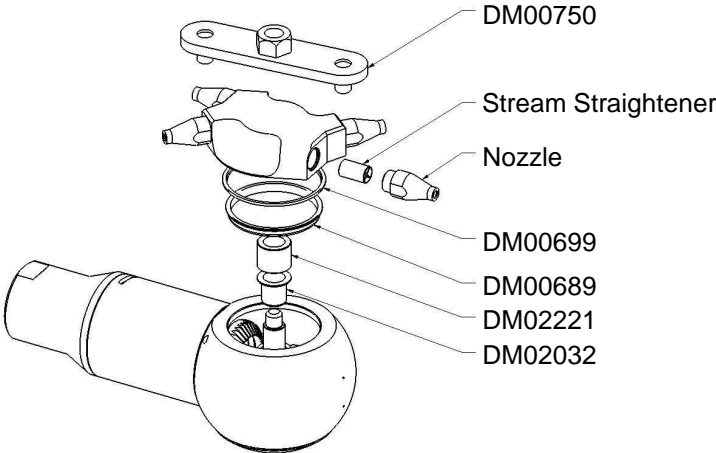

Figure 12: Nozzle head reassembly

Appendix

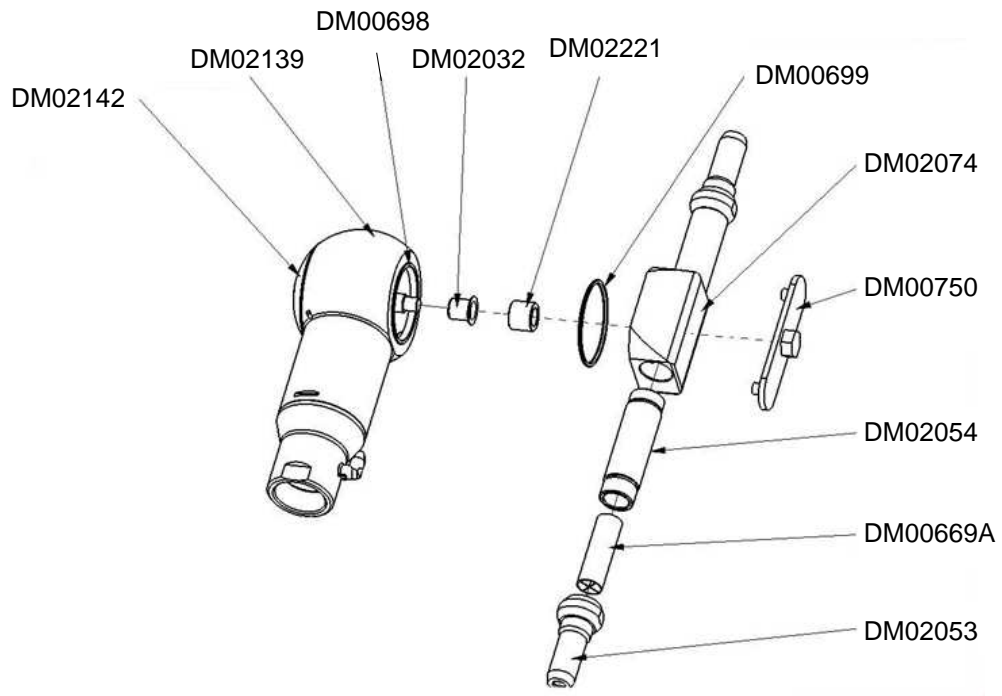

Figure 13: Hi-Capacity Orbitor

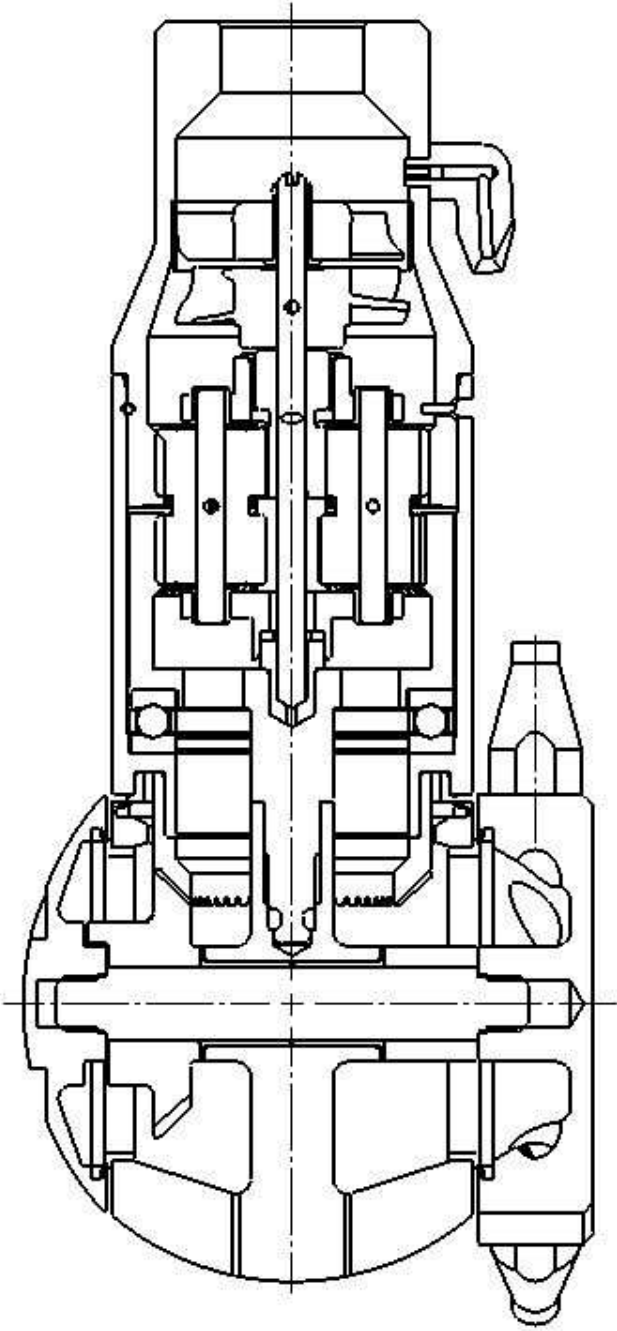

Figure 14: Section view of the Orbitor

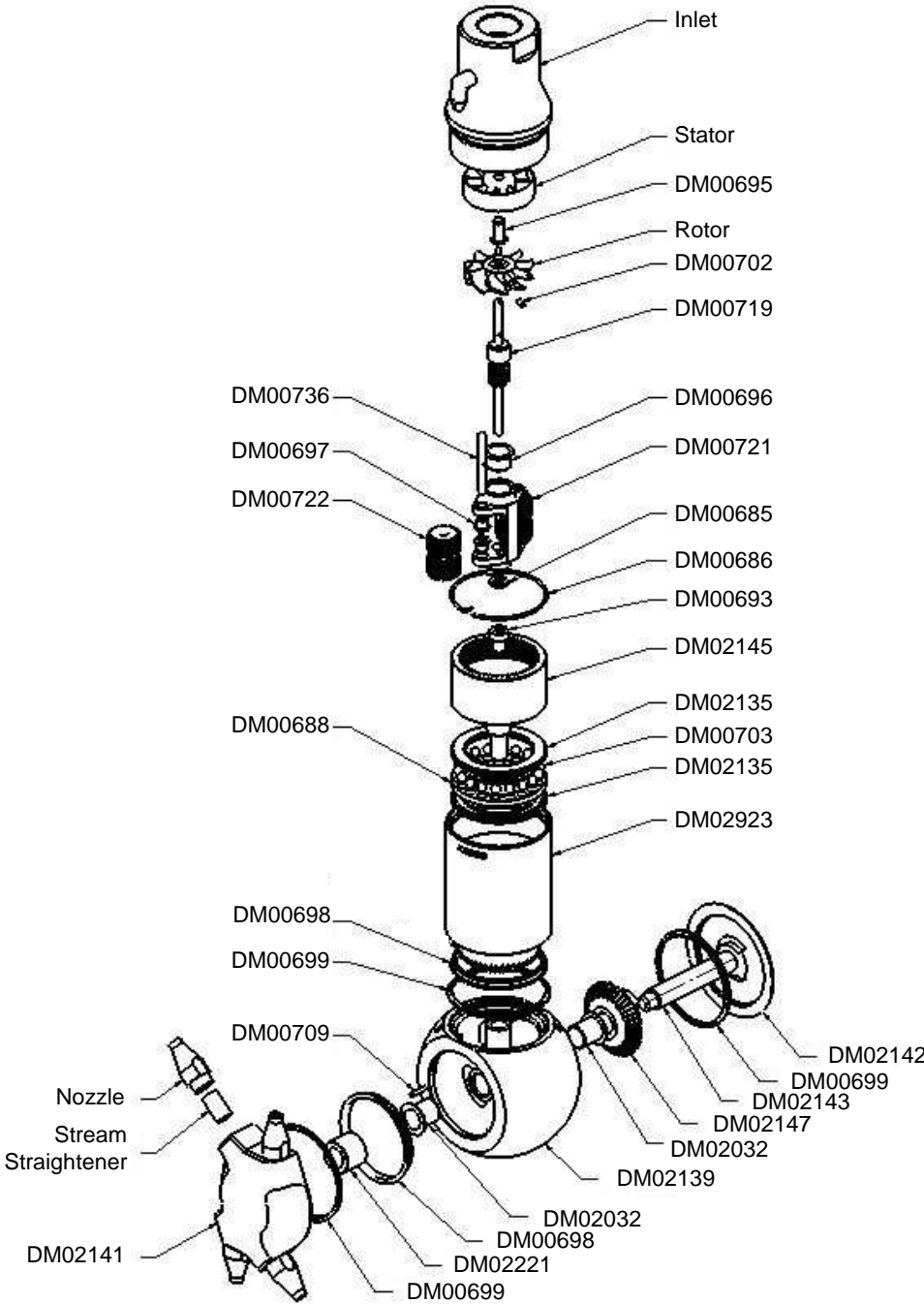

Figure 15: Exploded view of the Orbitor

Parts List

Please refer to Figure 15.

Part No.	Quantity	Description
DM00685	1	OB/3009 - Washer support (coated)
DM00686	1	OB/3010 - Clip spring
DM00688	1	OB/3012/2 - Thrust bearing cage
DM00693	1	OB/3020 - Spider bush
DM00695	1	OB/3022 - Stator bush
DM00696	1	OB/3023 - Cartridge bush
DM00697	4	Bush
DM00698	3	Ceramic seal insert
DM00699	3	Seal
DM00702	3	Hollow set screw, M4x8, dog point
DM00703	18	OB/3036 Ball, 7mm dia., (Hardened)
DM00709	1	Pin, 3.0 mm dia x 18.0 mm long
DM00719	1	OB/ASSY2 - Sun gear/Turbine shaft assembly
DM00721	1	OB/3001A - Planet gear
DM00722	1	OB/3001B - Planet gear 1/2
DM00736	2	OB/3008 - Planet shaft
DM02032	2	Nozzle head bush
DM02135	2	Thrust bearing race (electro-polished)
DM02139	1	Orbitor (H) Main body (electro-polished)
DM02141	1	Nozzle head, 4-way, Orbitor (H)
DM02142	1	Rear plate Orbitor (H)
DM02143	1	Blind shaft, Orbitor (H)
DM02144	1	Cartridge, Orbitor (H)
DM02145	1	Spider, Orbitor (H)
DM02147	1	Nozzle head bevel gear, 45T
DM02221	1	Spacer for blind shaft
DM02923	1	Body shell, Orbitor (H) (includes entry pipe bevel gear, 45T E-P)

Interchangeable Parts

Part No.	Description
Rotors	
DM02237	5° Positive
DM02137	20° Negative
DM02172	Full Rotor
DM02319	Flat Rotor
Stators	
DM02136	2 mm Cut Back
DM02173	4 Vane
DM02234	Full Stator
Nozzles x4	
DM02169	4.2 mm Diameter
DM02233	5.0 mm Diameter
DM02236	6.0 mm Diameter
DM01694	7.0 mm Diameter
DM02148	8.0 mm Diameter
Inlet Casing	
DM02227	1" NPT Female
DM02228	1" BSP Female
DM02160	1.5" NPT Female
DM02171	1.5" BSP Female
Hi Capacity Components – Refer to Figure 13	
DM02053	10.0 mm Diameter Nozzle
DM00747	12.5 mm Diameter Nozzle
DM00669A	Stream Straightener
DM02054	Nozzle Extension Tube
DM02074	Nozzle head, 2-way

Recommended Spare Parts

Service Tool Kit

Part No. 153203

Each kit includes:

Part No.	Qty	Description
DM00748	1	Spider removal tool
DM00749	1	Side plate tool, set of 2
DM00750	1	Nozzle head tool

Each part number in the tool kit can be purchased separately.

Rebuild Kits

Three rebuild kits are available depending on the level of service your Orbitor has experienced. A detailed list of the items supplied in each kit is shown on the next page.

Kit A, Part No. 178121

The basic kit that provides replacement of the seals.

Kit B, Part No. 178122

The standard kit that provides replacement of the seals and the bushings.

Kit C, Part No. 153417

The complete kit that provides replacement of the seals, bushings, and ceramic seal inserts.

Orbitor Rebuild Kit Contents

Part No.	Qty	Description	Material	Kit A	Kit B	Kit C
DM00686	1	Spring Clip	17-7 PH Stainless Steel (Werkstoff 1.4568)	X	X	X
DM00693	1	Spider bush	PTFE + 10% Carbon Fill		X	X
DM00695	1	Stator bush	PTFE + 10% Carbon Fill		X	X
DM00696	1	Cartridge bush	PTFE + 10% Carbon Fill		X	X
DM00697	4	Bush	PTFE + 10% Carbon Fill		X	X
DM00698	3	Seal insert	Stainless Steel Tech 28 Ceramic Coated			X
DM00699	3	Seal	ACoflon 212CF (PTFE + 10% Carbon-Fiber)	X	X	X
DM00709	1	Pin, 3.0 mm dia x 18.0 mm long	316L Stainless Steel	X	X	X
DM02032	2	Nozzle head bush	PTFE + 10% Carbon Fill		X	X
DM02922	1	Gear bush	PTFE + 10% Carbon Fill		X	X