

# HydroWhirl® Disc



(HWD) Powerful Submersible Rotating Tank Cleaner



## DESIGN FEATURES

- Fluid-driven, self-flushing
- Fully submersible, clog-resistant
- Powerful flat spray nozzle inserts
- Hydrostatic wear-free PTFE slide bearing for longer life
- Made from FDA-compliant, 316L SS
- For cleaning medium-sized tanks

## SPRAY CHARACTERISTICS

- Vigorous spray action
- Spray Angles:** Complete 360° spray coverage
- Flow Rates:** 96.3 to 227 L/min
- Max Temperature:** 194°F/90°C

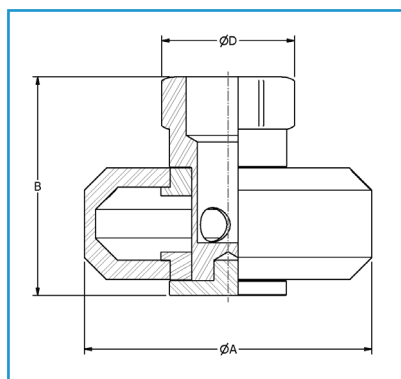

## DIMENSIONS IN MILLIMETERS

Pipe Size	A	B	D	Weight (grams)
1"	99	73.7	40.6	1162

## HYDROWHIRL® DISC FLOW RATES

Materials: 316L stainless steel body; PEEK slide-bearing

Female Connection Type	Nozzle Number	Spray Angles	Flow Rate (LPM) @ Differential Pressure (bar)					Maximum Free Passage	Coverage Dia. @ 2 bar
			0.7	1	2	3	4		
			bar	bar	bar	bar	bar		
1" NPT	HWD-50	360°	96.3	115	162	197	227	3.30	3.6